

Nevio Highbay Light



Features

- Ideally designed for applications in warehouses, gyms, manufacturing, airplane hangers and large retail outlets.
- With an enclosed power supply and covered optics, these units are designed for durability in industrial applications, yet provide the aesthetics required in retail applications.
- No harmful UV & IR Radiations
- Multiple angle adjustment option in luminaires



Suspended

Colour Rendering Index
≥70



IP Rating
IP65

5 years Standard Warranty
warranty

TECHNICAL DATA SHEET - NEVIO - 19306 - HIGHBAY LIGHT



TECHNICAL DATA

Product Data	Highbay Light
Lamp Type	EPISTAR LED
Wattage	100W, 150W, 200W
Color Temperature	3000K, 4000K, 6000K
Rated Luminaire Efficiency	150lm/W
IP Rating	65
Beam Angle	90°
Voltage	AC220-240V
Frequency Range	50-60 Hz
CRI	Ra>80
Power Factor	>0.9
Operating Temperature	-20°C ~ +50°C
IK Rating	IK10
THD	<20%
Material	ADC12 aluminum heatsink, outdoor powder coating
Finish	Black
Life Span	50,000 Hours
Warranty	5 Years
Applications	Warehouse, Industrial, etc.

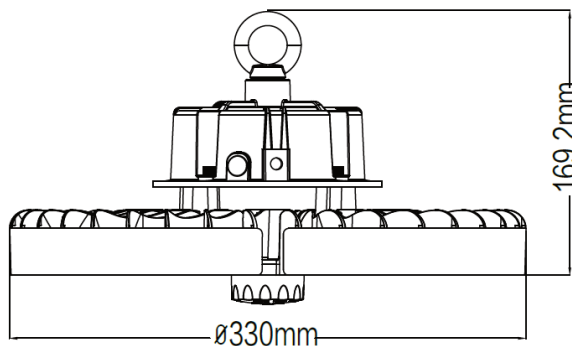
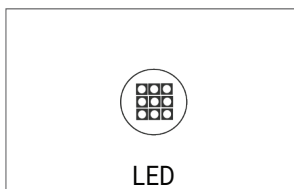

TECHNICAL OPTIONS

Beam Angle	70°/120°
Installation	Hook, Wide Bracket & Narrow Bracket
Control	1-10V, DALI
Optional	Plug&play sensor, Emergency Kit

TECHNICAL DATA SHEET - NEVIO - 19306 - HIGHBAY LIGHT

SENSOR FUNCTION (OPTIONAL)



Sensor Function



Sensor interface

+



Sensor Module



Microwave Sensor

ACCESSORIES (OPTIONAL)

1. PC Cover



2. Dustproof Cover

