

FLOOD/SPIKE LIGHT

Installation Manual

Thanks for using our product, our product is produced based on national standards. In order to install the lamp correctly, please check carefully this installation manual. Installation or maintenance operations must be worked by professional electrician. Please don't connect the power before installation or maintenance. The wrong installation and maintenance, or don't follow this manual, it will cause electrocuted.

1. Product installation requirements

- 1.1 Prepare all accessory of lamp installation.
- 1.2 Please be sure lamp power off during the installation or maintenance.
- 1.3 The using voltage can't exceed rated voltage.
- 1.4 The power cable specification must be CCC certificated and waterproof.
- 1.5 Please don't use the lamp in the corrosion, inflammability and Explosive environment.
- 1.6 The installation method as below pictures:

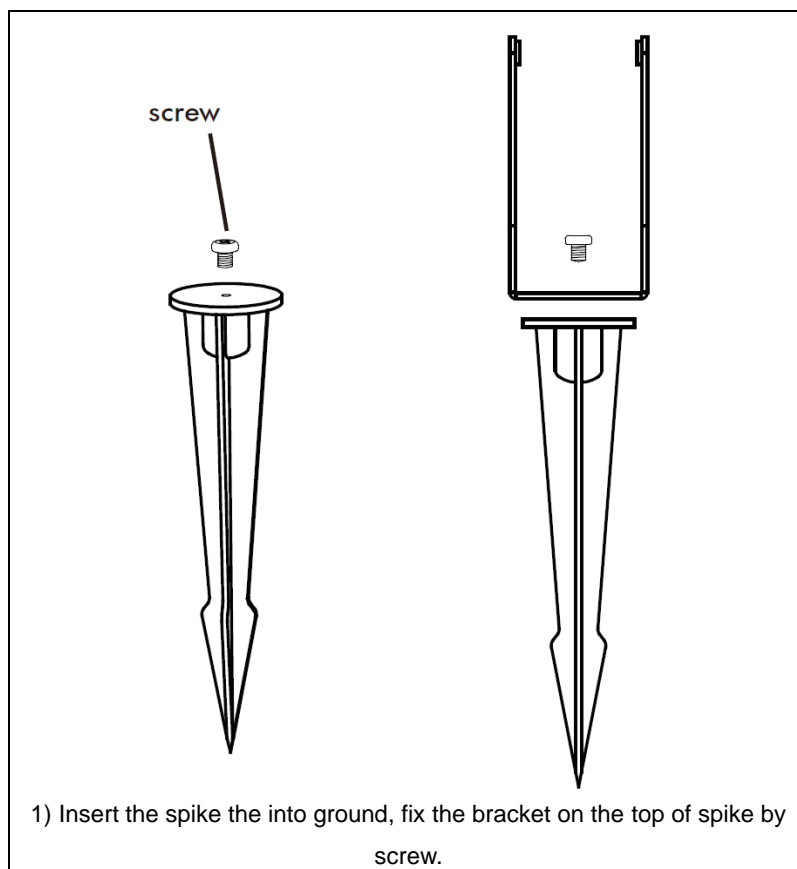

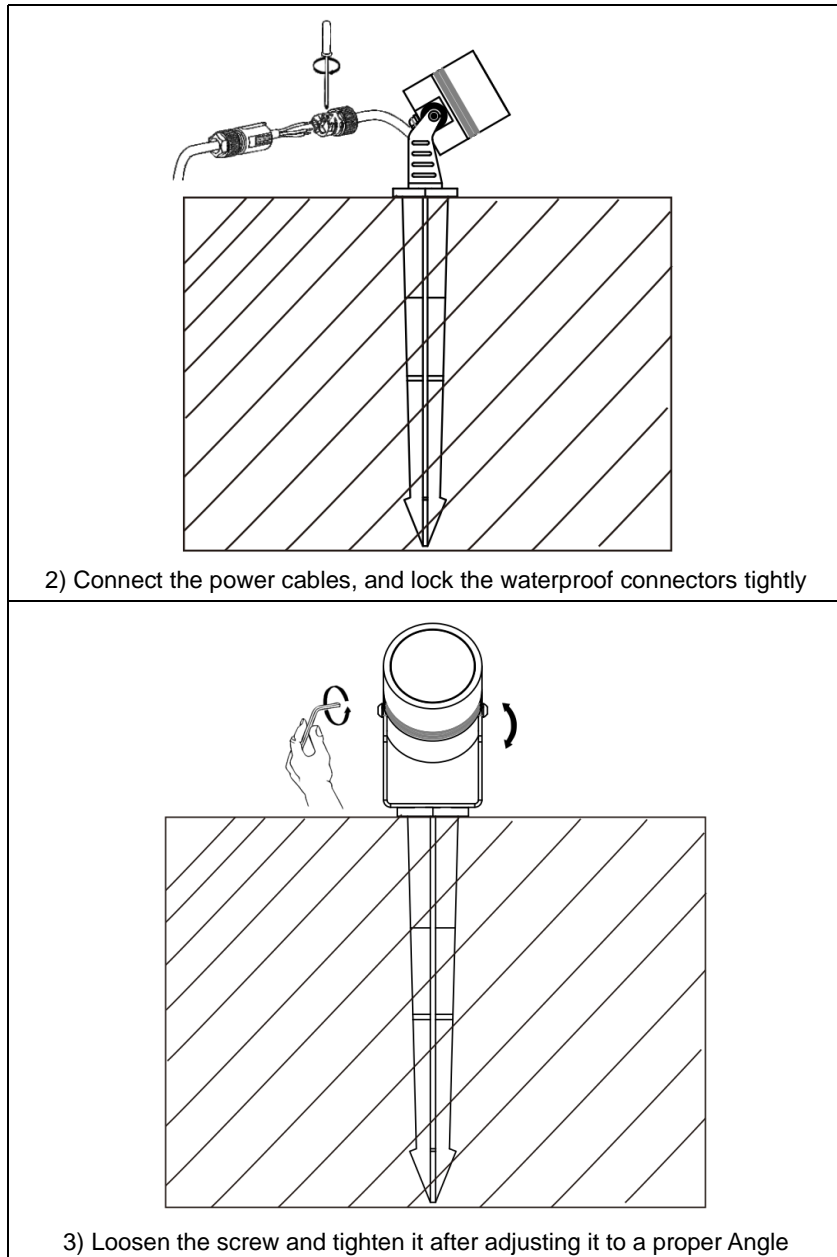

2. Two Cable connection way

(1) Male&female cable connection:



Rotated the nut to location notch, and push back the nut, Adjust the male&female connect at the same level, so that it can lock mutual tightly, then push and tighten the female connector.

(2) Waterproof junction box:

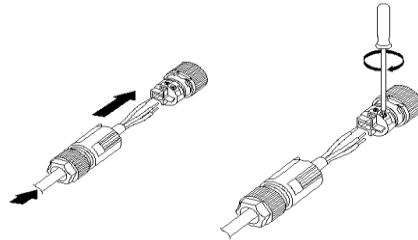

Connect the lamp power with driver power cable, and lock the waterproof connector

Pls ensure that all cable connection is correct, so that can turn on the lamp and finish installation.

(Low voltage lamp can't connect AC220V directly, it must connect constant voltage driver firstly.)

Cable connection diagram:

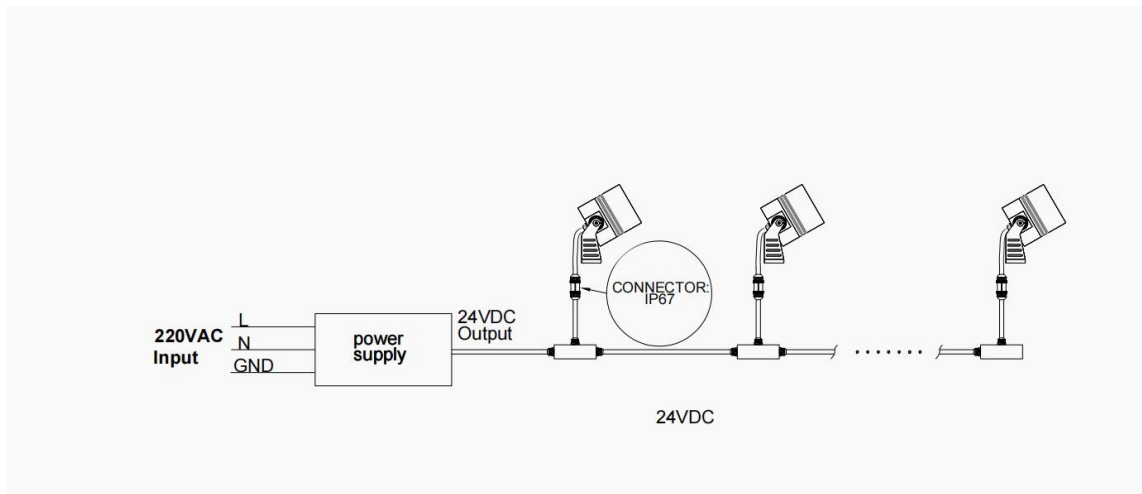

3. Note

In order to avoid the lamp breakage, fall, electric shock, fire and other accidents that threaten personal safety, please strictly follow the installation and use instructions, can't modify the lamp and change lamp inner electrical parts by yourself.

3.1 The power supply can't exceed the rated range (input voltage AC220V-240V, frequency 50/60Hz) . Using lamp over the rated voltage for a long time, it will cause the lamp overheating and broken.

3.2 Before installing the luminaires, the power supply need to cut off to prevent electric shock, and the products shall be powered on only after the installation is completed.

3.3 The lamp can't install at the heat source and corrosive gases place, so as not to affect the lamp life time.

3.4 Pls ensure that install area can bear 10 times of product weight, before you install the lamp. And install the lamp at no vibration/swing/fire place.

3.5 Lamp external flexible cable or cable (cable requirements IP67) can not be replaced; if the flexible cable damage, the lamp should be scrapped.

3.3 The lamp external cable(require IP67) can't replaced.If the cable is damage, then the lamp is useless.

3.7 The light source of lamp need to be replaced by the manufacturer and its agent or similar qualified people.

3.8 This lamp is designed and manufactured in according to the requirement 《luminaires part 2-1: special requirements, fixed general luminaires》