

Installation Instruction

(please read carefully before instruction and save)

Before installation and use, please read carefully the following instruction of correct installation and matters needing attention. Please keep the instruction properly for your convenient reference at any time.

- Accessories:** 1.Lamp .
2.colloidal particles , setscrews
3.Installation Instruction

Installation Steps:

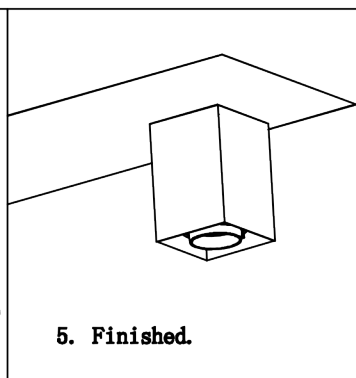
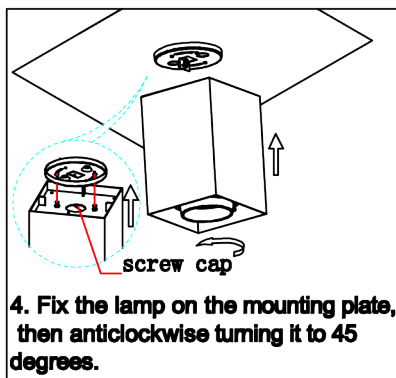
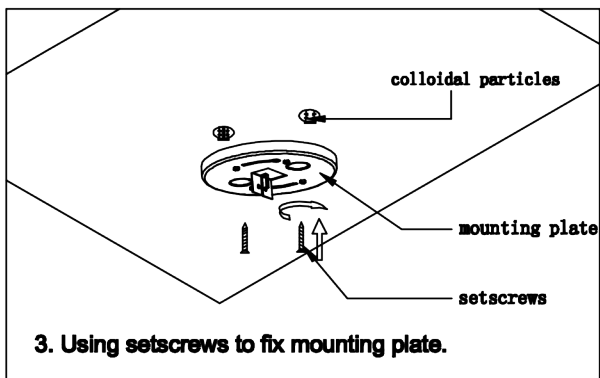
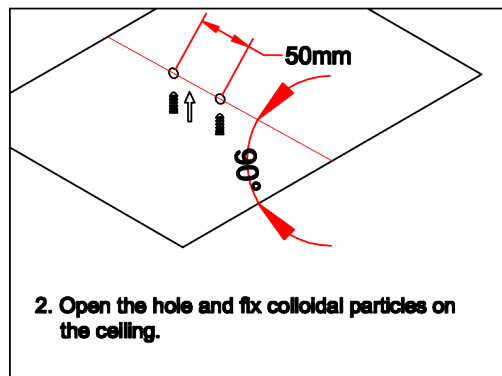
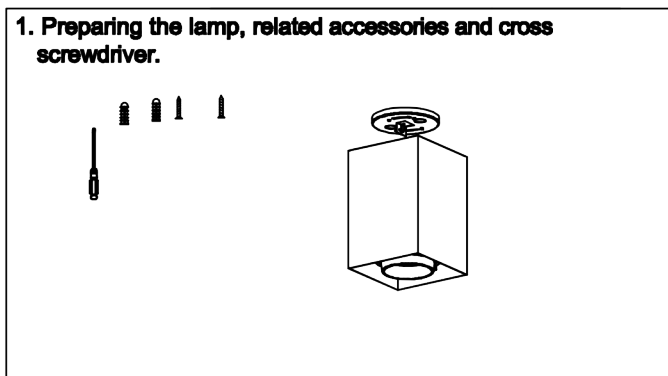

Attentions:

- ! Indoor use only, not suitable in vibration, dust, and over heat temperature environment; otherwise it is easily to cause fire and electric shock.
- ! Do shut off the power before install, clean and maintain the light, to avoid electric shock.
- ! For the track light, Please be sure that the product is away from the surrounding objects at least 100mm, and the minimum distance between the light and the surface of the object should be at least 500mm, otherwise it easily to cause fire and fault.
- ! Don't cover the light with thermal insulation material or similar materials at any case.
- ! Don't disassemble the internal structure of the light at any time.
- ! Cut off the power when the light works abnormally, and contact our service center or our specialist.

Maintenance:

For the safe and high efficient use of our products, please do overall cleaning and check up every 6 months. You can use hair dryer or dry soft brush to remove the surface dust, and then use soft cloth with alcohol to clean the product, because the dust does not only affect the out looking but also influence the heat dissipation performance of the light and shorten its lifespan. Please don't use water, gasoline or thinner to clean the light; otherwise it will damage the light or its color. Please arrange examine by specialists once every 3 or 5 year, replace the broken components or the light which does not work or which exceeded the lifespan to avoid the fire or any other accident.

